

(No Model.)

J. A. PLUMMER, Jr., & T. GAINFORD.

HAND TURNING TOOL.

No. 270,474.

Patented Jan. 9, 1883.

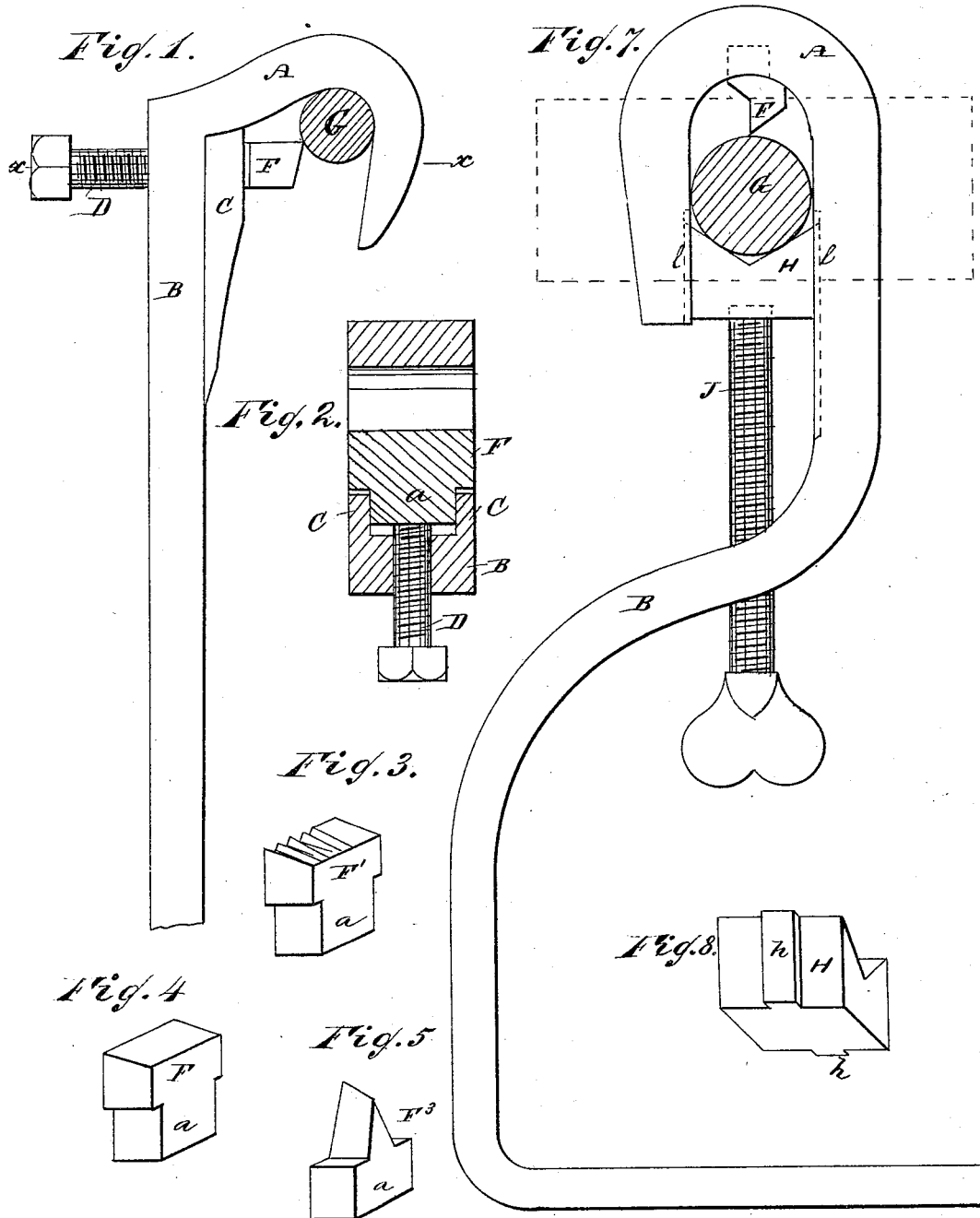

WITNESSES:

Wm. H. Boston
C. Beddwick

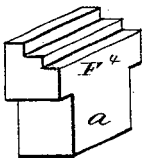

Fig. 6.

INVENTOR:

J. A. Plummer Jr.
T. Gainford
BY *Wm. H. Boston*
ATTORNEYS.

UNITED STATES PATENT OFFICE.

JOHN A. PLUMMER, JR., AND THOMAS GAINFORD, OF NEWARK, CALIFORNIA.

HAND TURNING-TOOL.

SPECIFICATION forming part of Letters Patent No. 270,474, dated January 9, 1883.

Application filed May 2, 1882. (No model.)

To all whom it may concern:

Be it known that we, JOHN A. PLUMMER, Jr., and THOMAS GAINFORD, of Newark, in the county of Alameda and State of California, have invented a new and Improved Hand Turning-Tool, of which the following is a full, clear, and exact description.

The object of our invention is to provide a new and improved hand-tool for turning rods, pivots, or pintles without the use of a lathe.

The invention consists in the peculiar construction and arrangement of the parts, as hereinafter more fully set forth, and pointed out in the claim.

Reference is to be had to the accompanying drawings, forming part of this specification, in which similar letters of reference indicate corresponding parts in all the figures.

Figure 1 is a longitudinal elevation of our improved turning-tool. Fig. 2 is a horizontal sectional view of the same on the line *x x*, Fig. 1. Fig. 3 is a perspective view of the first cutting-bit. Fig. 4 is a perspective view of the second cutting-bit. Fig. 5 is a perspective view of the pipe or rod cutting bit. Fig. 6 is a perspective view of the pipe or rod holding bit. Fig. 7 is a side elevation of a modification of our improved hand turning-tool. Fig. 8 is a perspective view of the clamping-blocks of the same.

A hooked arm, A, is made integral with or attached to one end of a bar or handle, B, which is provided at its upper end and on the inner side with two longitudinal jaws, C, between which the tenons *a* of the cutting-bits fit. A set-screw, D, provided at the outer end with a head or with wings for turning it, passes through the upper part of the bar or handle at right angles to the same, so that the inner end of this set-screw projects toward the hook A.

In the modification shown in Fig. 7 the handle B is curved and bent, so as to adapt it to be used in reaching pivots or pintles on cross-heads or on other like objects which cannot be reached with a straight handle. The cutter-bit F is contained in a recess in the inner edge of the upper part of the hook, and the rod or pivot G (see Fig. 7) is pressed against

it by a pressure-block, H, adapted to slide between the shanks of the hook, which block is pressed against the pivot or rod G by a set-screw, J, passing through the curved handle. The bit F' is used to turn off the rod in its rough state, and it planes off the bar, leaving it tolerably smooth. Then the bit F is used, which turns down the surface of the rod or pivot true and smooth.

In the device shown in Figs. 1 and 2 the bit is pressed against the rod or pivot G with more or less pressure, as may be necessary, by the set-screw D, and in the device shown in Fig. 7 this pressure is obtained by means of the screw J.

The bit F³ (shown in Fig. 5) is used to cut tubes or rods, and the bit F⁴ is used to hold pipes or rods in the same manner as they are held by pipe-tongs. The block H is provided with end ridges, *h*, fitting in longitudinal grooves *l* in the sides of the shanks of the implement shown in Fig. 7 to guide this block H up and down between the shanks of the hook.

By turning the above-described tool or its modification around the object to be planed, rods, pintles, pivots, wrist-pins, and like parts of machinery can be turned true and smooth very easily and rapidly.

This implement is very compact, can easily be stored in a locomotive or engine-room, and turns a rod or pivot as well as an expensive and cumbersome lathe.

Having thus fully described our invention, we claim as new and desire to secure by Letters Patent—

The combination, with the curved bar B, provided with a hook, A, having a recess in the inner edge of its upper part, and grooves *l* in its sides, of the cutter-bit F, grooved pressure-block H, having end lugs, *h*, fitting in the grooves *l*, and screw J, substantially as described, and for the purpose set forth.

JOHN ALLEN PLUMMER, JR.
THOMAS GAINFORD.

Witnesses:

W. A. YATES,
C. PRAG.